

PART NUMBER	DESCRIPTION
20021-001	ASSEMBLY, AIR CONDITIONER FM9R, 18.50L X 11.50W X 11.25H, 120V SIDE
20021-011	ASSEMBLY, AIR CONDITIONER FM9R, 18.50L X 11.50W X 11.25H, 120V SIDE, WITH OPTIONAL HEAT
20021-101	ASSEMBLY, AIR CONDITIONER FM9R, 18.50L X 11.50W X 11.25H, 230V SIDE
20021-111	ASSEMBLY, AIR CONDITIONER FM9R, 18.50L X 11.50W X 11.25H, 230V SIDE, WITH OPTIONAL HEAT

FLAGSHIP MARINE, INC.				
REV.	ZONE	DESCRIPTION	DATE	ENG APPROVAL
01		INITIAL CHECK-IN	8/13/2010	
02		ADDED ITEMS 20 & 21	8/30/2010	
03		ADDED 50025-001; REPLACED 3/8" CONDENSER HARDWARE WITH 5/16"	10/13/2010	

2. PREFERRED LIMITS AND FITS PER ANSI B4.1 (INCHES).
1. DIMENSIONING & TOLERANCING PER ASME Y14.5M.

NOTES:

27	ML6360000A20000	M6 DIN 127 A2 SPLIT LOCK WASHER, 18-8 SS	4	4	4	4
26	M82550012A20000	M6-1.0 X 12MM DIN 933 CLASS A2 CAP SCREW, SS	4	4	4	4
25	80022-001	WELDMENT, BASE, AIR CONDITIONER, FM9R, SIDE	1	1	1	1
24	80021-001	WELDMENT, DRAIN PAN, EVAPORATOR, AIR CONDITIONER, FM9R, SIDE	1	1	1	1
23	70090-001	DETAIL, PLATE, DECORATIVE CONDENSER COVER, FM9R	1	1	1	1
22	70088-001	FABRICATION, BRACKET, CONDENSER, AIR CONDITIONER, FM9R, SIDE	1	1	1	1
21	70087-001	FABRICATION, BRACKET, BLOWER, AIR CONDITIONER, FM9R	1	1	1	1
20	70086-001	FABRICATION, LID, ENCLOSURE, HEATER COIL, AIR CONDITIONER, FM9R	-	1	-	1
19	70085-001	FABRICATION, ENCLOSURE, HEATER COIL, AIR CONDITIONER, FM9R	-	1	-	1
18	70084-001	FABRICATION, SHROUD, EVAPORATOR, AIR CONDITIONER, FM9R, SIDE	1	1	1	1
17	60210-001	EVAPORATOR, 9000 MBTU, 10HX10.13W, 2 ROW	1	1	1	1
16	60131-001	GROMMET, 11/16" PUSH-IN LOCKING, NYLON	-	1	-	1
15	60062-001	THERMAL LIMIT SWITCH, 130 DEGREE	-	1	-	1
14	60060-001	THERMAL LIMIT SWITCH, 110 DEGREE	-	1	-	1
13	60031-001	HEATER ELEMENT, COIL, 45"L, 8MM, 1700W, 120VAC, DBL END THRD BULKHEAD	-	1	-	1
12	60021-001	BLOWER, PSC, SHADED POLE, 1TDR7, 115V	1	1	-	-
11	60009-001	BLOWER, PSC, SHADED POLE, 1TDR8, 230V	-	-	1	1
10	50025-001	DETAIL, SPACER, .375 OD X .335 ID, 304 SS	3	3	3	3
9	50002-001	FABRICATION, TUBING, AIR CONDITIONER, FM9R, SIDE	1	1	1	1
8	2R12S3R126A-6A	COMPRESSOR, 1PH, 60 Hz, 115V	1	1	-	-
7	2R10S3R236A-6A	COMPRESSOR, 1PH, 60 Hz, 230V	-	-	1	1
6	20015-001	ASSEMBLY, CONTROL BOX, SELF CONTAINED, A/C, UNIVERSAL	1	1	1	1
5	1131943	#8-18 X 1/2" HWH #3 PT SELF DRILLING SCREW, 410 SS	16	20	16	20
4	0172789	5/16" X 1.13" FENDER WASHER, 18-8 SS	3	3	3	3
3	72396	#8-32 x 3/8" PHMS 18-8 SS	-	2	-	2
2	70861	5/16-18 NYLOCK NUT, 18-8 SS	3	3	3	3
1	41424	RIVET 3/16" DIA .062-.125" GRIP RANGE, SSB62S STAINLESS	18	18	18	18

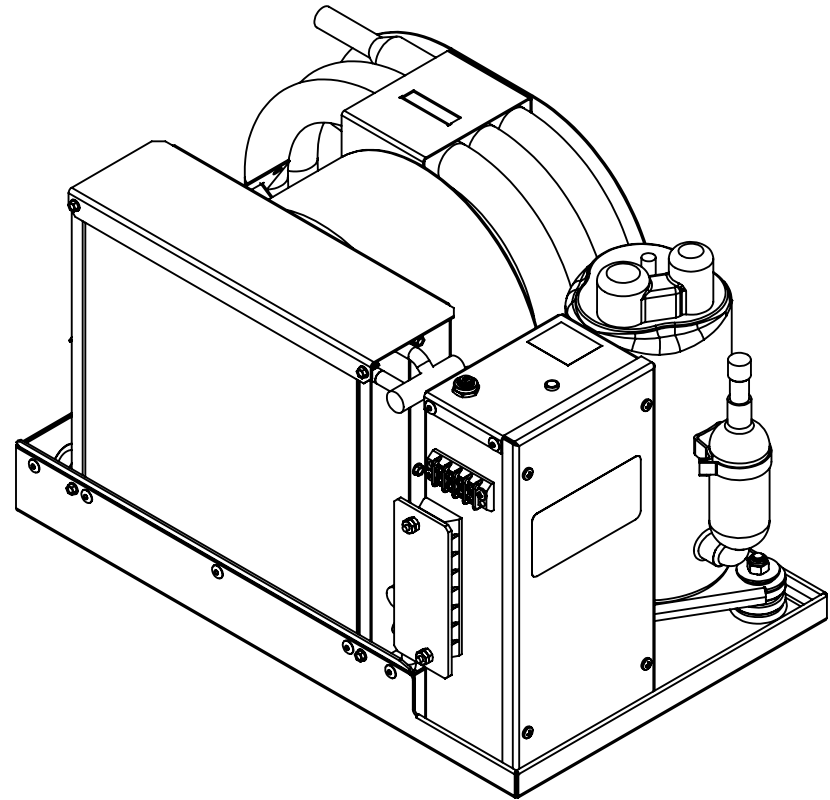

20021-011 SHOWN
SEE SHEET 3 OF 4 FOR DIMENSIONS

ITEM NO.	PART NUMBER	DESCRIPTION	20021-001/QTY.	20021-011/QTY.	20021-101/QTY.	20021-111/QTY.
----------	-------------	-------------	----------------	----------------	----------------	----------------

FLAGSHIP MARINE, INC. BILL OF MATERIALS

Flagship Marine
COMPONENTS
FLAGSHIP MARINE, INC.
2427 SE DIXIE HIGHWAY
STUART | FLORIDA | 34996 | USA
(772) 283-1609 | (800) 316-6426
FAX (772) 283-4611

PROPRIETARY AND CONFIDENTIAL
THIS DOCUMENT CONTAINS INFORMATION PROPRIETARY TO FLAGSHIP MARINE, INC. NO PART MAY BE REPRODUCED, USED IN ANY FORM, OR STORED ELECTRONICALLY WITHOUT THE WRITTEN PERMISSION OF FLAGSHIP MARINE, INC.

UNLESS OTHERWISE SPECIFIED:		NAME	DATE
DIMENSIONS ARE IN INCHES		DRAWN	SWC 8/2/2010
TOLERANCES:		CHECKED	TCM -
FRACTIONS ± 1/32		ENG APPR.	TCM -
ANG: MACH ± 0°30' BEND ± 2°		MFG APPR.	TCM -
DECIMALS .XX ± .01		Q.A.	EAS -
.XXX ± .005		PERP STRAIGHTNESS ± .003/IN	
HOLE Ø .XX ± .005		FLATNESS ± .005/IN	
INTERPRET GEOMETRIC TOLERANCING PER: ASME Y14.5M		THREADS:	
MATERIAL		EXTERNAL - CLASS 2A	
FINISH		INTERNAL - CLASS 2B	
NEXT ASSY	USED ON	MACHINED SURFACES: ✓ U.O.S	
APPLICATION		DO NOT SCALE DRAWING	

TITLE: ASSEMBLY, AIR CONDITIONER FM9R, 18.50L X 11.50W X 11.25H, SIDE

PART NO. 20021-XX1

SIZE DWG. NO. REV
B FM20021 **03**

OLD PART NO. -

SCALE: 1:5 WGT: 79.23 LBS SHEET 1 OF 4

PART NUMBER	DESCRIPTION
20021-002	ASSEMBLY, AIR CONDITIONER FM9R, 18.50L X 11.50W X 11.25H, 120V TOP
20021-012	ASSEMBLY, AIR CONDITIONER FM9R, 18.50L X 11.50W X 11.25H, 120V TOP, WITH OPTIONAL HEAT
20021-102	ASSEMBLY, AIR CONDITIONER FM9R, 18.50L X 11.50W X 11.25H, 230V TOP
20021-112	ASSEMBLY, AIR CONDITIONER FM9R, 18.50L X 11.50W X 11.25H, 230V TOP, WITH OPTIONAL HEAT

2. PREFERRED LIMITS AND FITS PER ANSI B4.1 (INCHES).
1. DIMENSIONING & TOLERANCING PER ASME Y14.5M.
NOTES:

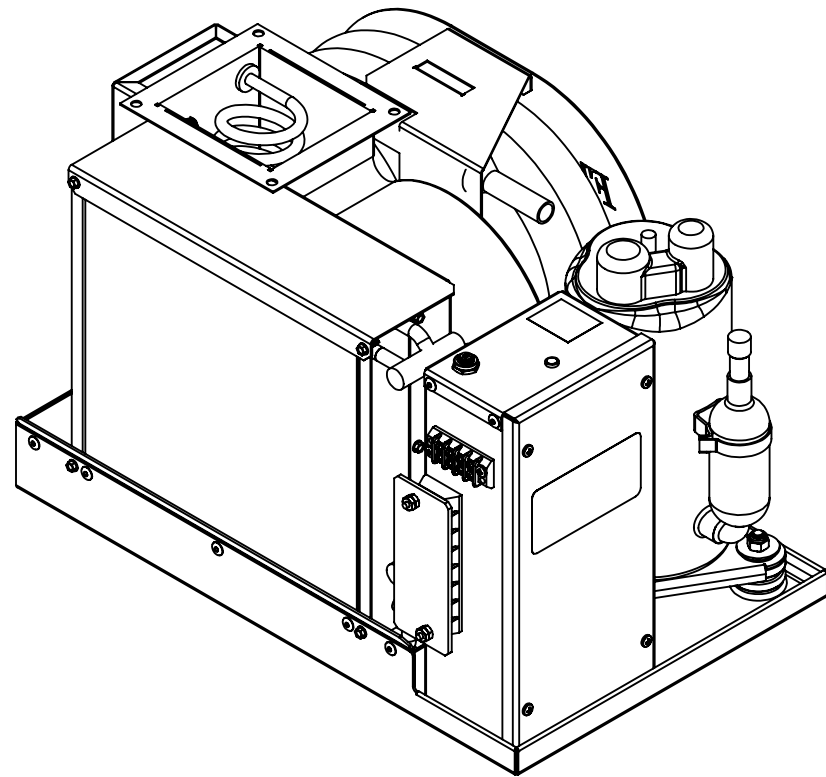

20021-012 SHOWN
SEE SHEET 4 OF 4 FOR DIMENSIONS

27	ML6360000A20000	M6 DIN 127 A2 SPLIT LOCK WASHER, 18-8 SS	4	4	4	4
26	M82550012A20000	M6-1.0 X 12MM DIN 933 CLASS A2 CAP SCREW, SS	4	4	4	4
25	80022-002	WELDMENT, BASE, AIR CONDITIONER, FM9R, TOP	1	1	1	1
24	80021-002	WELDMENT, DRAIN PAN, EVAPORATOR, AIR CONDITIONER, FM9R, TOP	1	1	1	1
23	70090-001	DETAIL, PLATE, DECORATIVE CONDENSER COVER, FM9R	1	1	1	1
22	70089-001	FABRICATION, BRACKET, CONDENSER, AIR CONDITIONER, FM9R, TOP	1	1	1	1
21	70087-001	FABRICATION, BRACKET, BLOWER, AIR CONDITIONER, FM9R	1	1	1	1
20	70086-001	FABRICATION, LID, ENCLOSURE, HEATER COIL, AIR CONDITIONER, FM9R	-	1	-	1
19	70085-001	FABRICATION, ENCLOSURE, HEATER COIL, AIR CONDITIONER, FM9R	-	1	-	1
18	70084-002	FABRICATION, SHROUD, EVAPORATOR, AIR CONDITIONER, FM9R, TOP	1	1	1	1
17	60210-001	EVAPORATOR, 9000 MBTU, 10HX10.13W, 2 ROW	1	1	1	1
16	60131-001	GROMMET, 11/16" PUSH-IN LOCKING, NYLON	-	1	-	1
15	60062-001	THERMAL LIMIT SWITCH, 130 DEGREE	-	1	-	1
14	60060-001	THERMAL LIMIT SWITCH, 110 DEGREE	-	1	-	1
13	60031-001	HEATER ELEMENT, COIL, 45"L, 8MM, 1700W, 120VAC, DBL END THRD BULKHEAD	-	1	-	1
12	60021-001	BLOWER, PSC, SHADED POLE, 1TDR7, 115V	1	1	-	-
11	60009-001	BLOWER, PSC, SHADED POLE, 1TDR8, 230V	-	-	1	1
10	50025-001	DETAIL, SPACER, .375 OD X .335 ID, 304 SS	3	3	3	3
9	50002-002	FABRICATION, TUBING, AIR CONDITIONER, FM9R, TOP	1	1	1	1
8	2R12S3R126A-6A	COMPRESSOR, 1PH, 60 Hz, 115V	1	1	-	-
7	2R10S3R236A-6A	COMPRESSOR, 1PH, 60 Hz, 230V	-	-	1	1
6	20015-001	ASSEMBLY, CONTROL BOX, SELF CONTAINED, A/C, UNIVERSAL	1	1	1	1
5	1131943	#8-18 X 1/2" HWH #3 PT SELF DRILLING SCREW, 410 SS	16	20	16	20
4	0172789	5/16" X 1.13" FENDER WASHER, 18-8 SS	3	3	3	3
3	72396	#8-32 x 3/8" PHMS 18-8 SS	-	4	-	4
2	70861	5/16-18 NYLOCK NUT, 18-8 SS	3	3	3	3
1	41424	RIVET 3/16" DIA .062-.125" GRIP RANGE, SSB62S STAINLESS	18	18	18	18

ITEM NO.	PART NUMBER	DESCRIPTION	20021-002/QTY.	20021-012/QTY.	20021-102/QTY.	20021-112/QTY.
----------	-------------	-------------	----------------	----------------	----------------	----------------

FLAGSHIP MARINE, INC. BILL OF MATERIALS



FLAGSHIP MARINE, INC.
2427 SE DIXIE HIGHWAY
STUART | FLORIDA | 34996 | USA
(772) 283-1609 | (800) 316-6426
FAX (772) 283-4611

PROPRIETARY AND CONFIDENTIAL

THIS DOCUMENT CONTAINS INFORMATION PROPRIETARY TO FLAGSHIP MARINE, INC. NO PART MAY BE REPRODUCED, USED IN ANY FORM, OR STORED ELECTRONICALLY WITHOUT THE WRITTEN PERMISSION OF FLAGSHIP MARINE, INC.

UNLESS OTHERWISE SPECIFIED:	NAME	DATE
DIMENSIONS ARE IN INCHES	DRAWN	SWC 8/2/2010
TOLERANCES:	CHECKED	TCM -
FRACTIONS ± 1/32	ENG APPR.	TCM -
ANG: MACH ± 0°30' BEND ± 2°	MFG APPR.	TCM -
DECIMALS .XX ± .01	Q.A.	EAS -
.XXX ± .005	PERP	∟ .003/IN
HOLE Ø .XX ± .005	STRAIGHTNESS	— .005/IN
INTERPRET GEOMETRIC TOLERANCING PER: ASME Y14.5M	FLATNESS	▭ .005/IN
MATERIAL	THREADS:	EXTERNAL - CLASS 2A
FINISH	INTERNAL - CLASS 2B	∅3/ U.O.S
NEXT ASSY	MACHINED SURFACES:	✓ U.O.S
USED ON		
APPLICATION	DO NOT SCALE DRAWING	

TITLE:	ASSEMBLY, AIR CONDITIONER FM9R, 18.50L X 11.50W X 11.25H, TOP		
PART NO.	20021-XX2		
SIZE	DWG. NO.	REV	
B	FM20021	03	
OLD PART NO.	-		
SCALE: 1:5	WGT: 79.39 LBS	SHEET 2 OF 4	

8 7 6 5 4 2 1

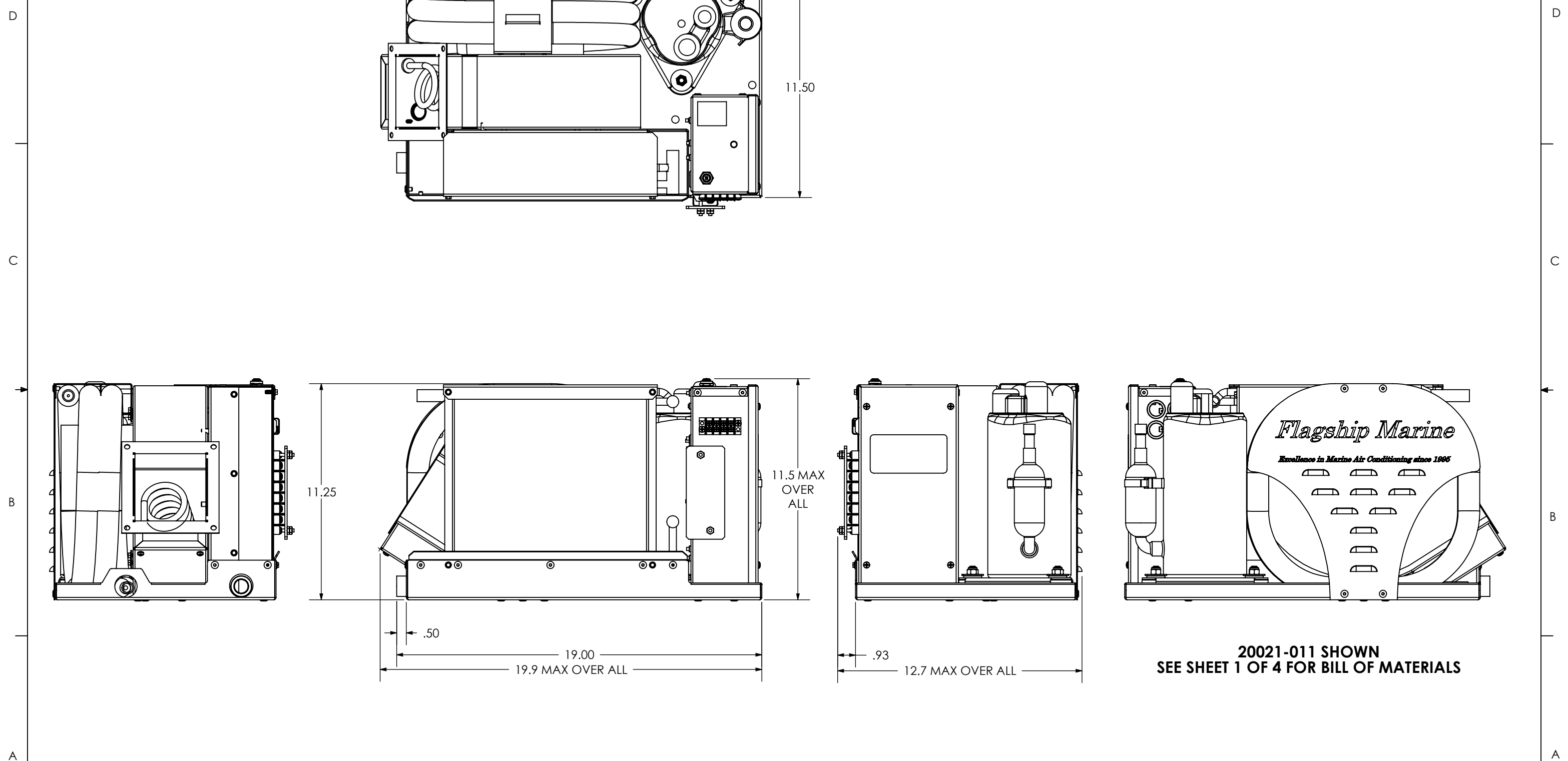

2021-011 SHOWN
SEE SHEET 1 OF 4 FOR BILL OF MATERIALS

 <p>Flagship Marine Commercial Quality Factory Direct Prices</p> <p>2427 SE DIXIE HIGHWAY STUART FLORIDA 34996 USA (772) 283-1609 (800) 316-6426 FAX (772) 283-4611</p>	DRAWN SWC	SIZE B	DRAWING NO. FM20021	REV 03
	CHECKED -	WGT: 79.23 LBS	SCALE: 1:5	SHEET 3 OF 4
	ENG APPR. -			

8 7 6 5 4 3 2 1

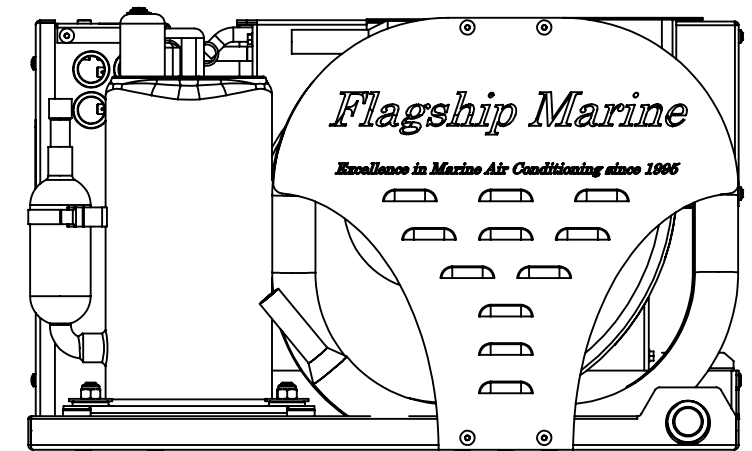
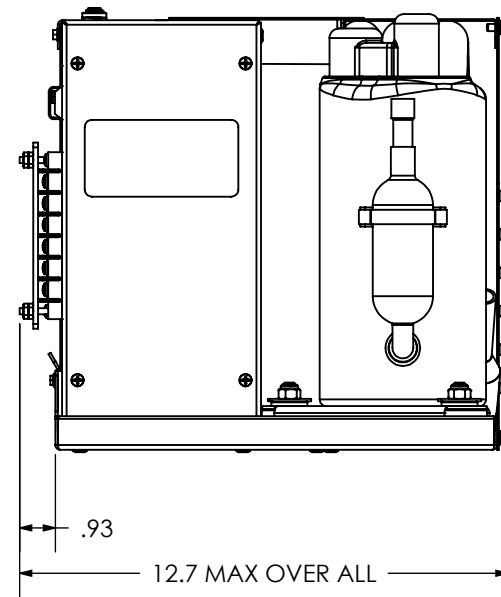
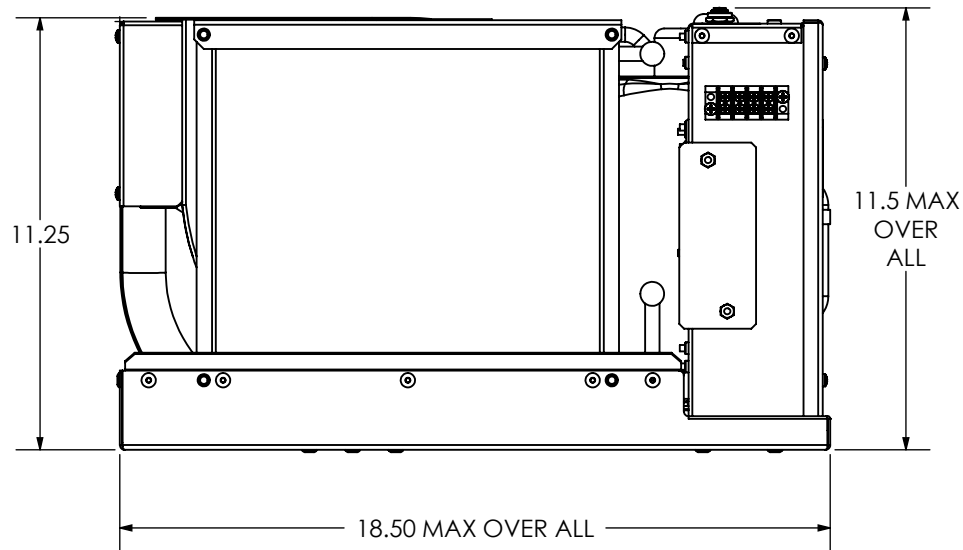
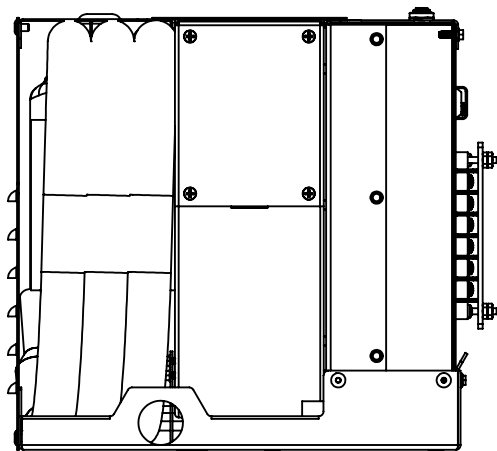
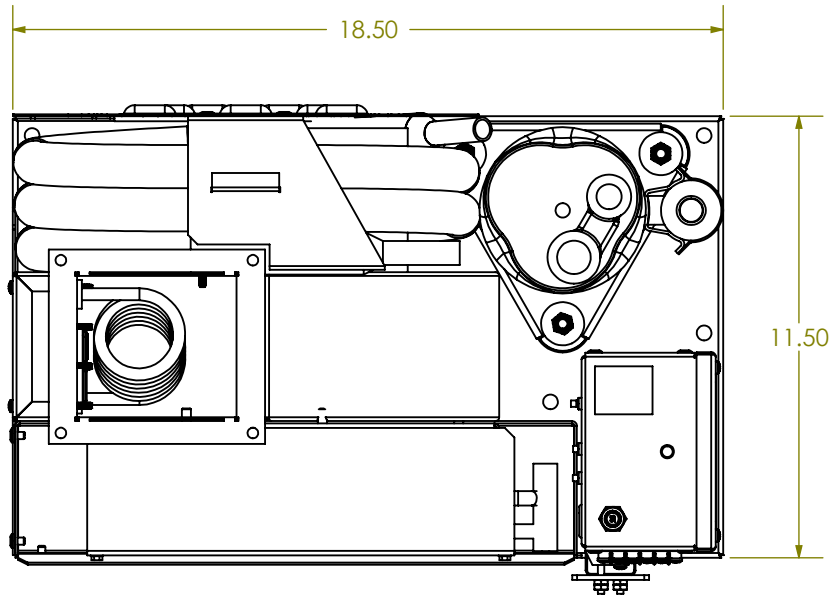

**2021-012 SHOWN
SEE SHEET 2 OF 4 FOR BILL OF MATERIALS**

Flagship Marine
Commercial Quality Factory Direct Prices

2427 SE DIXIE HIGHWAY | STUART | FLORIDA | 34996 | USA
(772) 283-1609 | (800) 316-6426 FAX (772) 283-4611

DRAWN	SWC	SIZE	DRAWING NO.	REV
CHECKED	-	B	FM20021	03
ENG APPR.	-	WGT: 79.40 LBS	SCALE: 1:5	SHEET 4 OF 4