

FLAGSHIP MARINE, INC.				
REV.	ZONE	DESCRIPTION	DATE	ENG APPROVAL
01	-	INITIAL CHECK-IN	2/25/2011	-

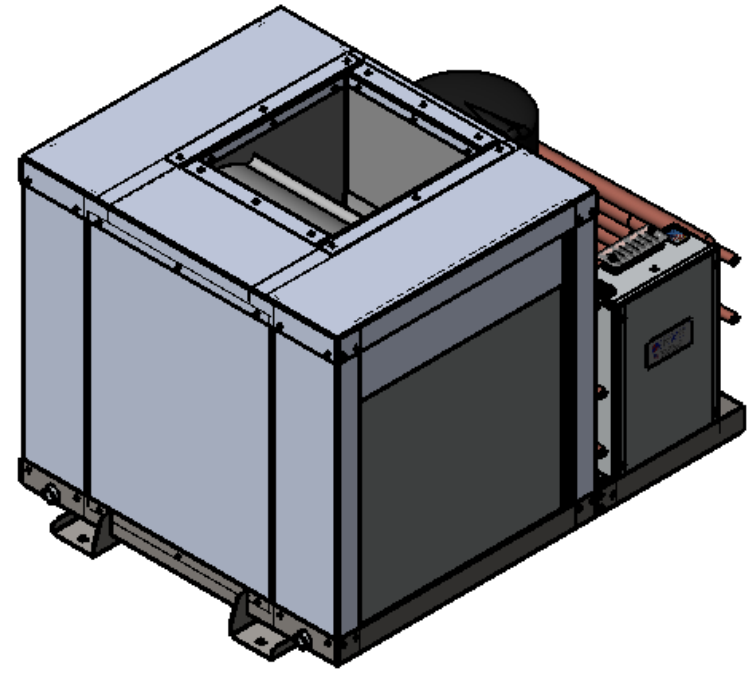

20051-001
ASSEMBLY, AIR CONDITIONER FM72S-H, 39L X 28W X 26H, TOP

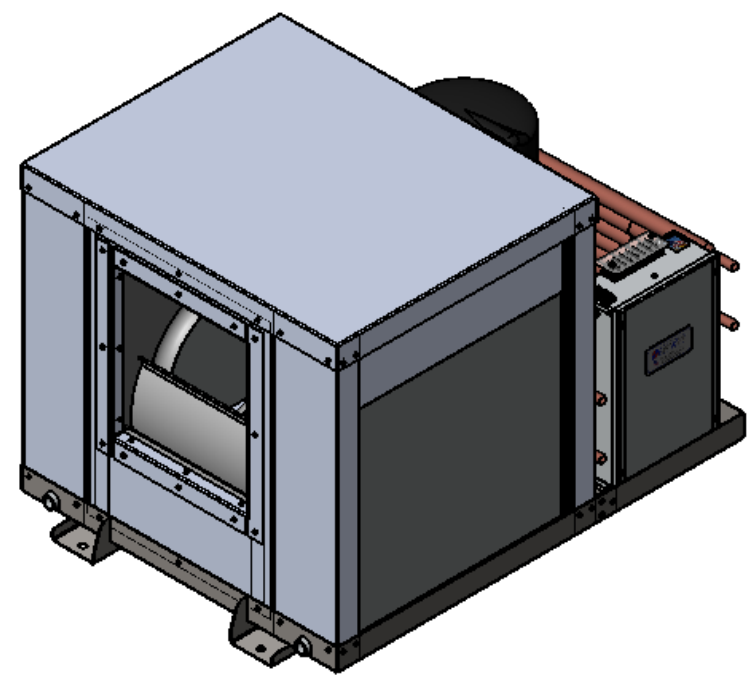

20051-002
ASSEMBLY, AIR CONDITIONER FM72S-H, 39L X 28W X 26H, SIDE

ITEM NO.	PART NUMBER	DESCRIPTION	20051-001/QTY.	20051-002/QTY.
27	ZR61K3-PFV-930	COMPRESSOR, 1PH, 60 Hz, 208-230V	1	1
26	Selected Wide FW 0.375		4	-
25	Regular LW 0.375		4	4
24	HNUT 0.3750-16-D-N		4	-
23	80055-001	WELDMENT, PANEL, ACCESS, AIR CONDITIONER, FMAC60S-H	-	1
22	80054-001	WELDMENT, LID, AIR CONDITIONER, FMAC60S-H	1	-
21	80053-001	WELDMENT, DRAIN PAN, EVAPORATOR, FMAC60S-H	2	2
20	80052-001	WELDMENT, BASE, AIR CONDITIONER, FMAC60S-H	1	1
19	70081-002	FABRICATION, BRACKET, BLOWER, AIR CONDITIONER, FMAC60/120/180SOH	-	2
19	70081-001	FABRICATION, BRACKET, BLOWER, AIR CONDITIONER, FMAC60/120/180SOH	2	-
18	70079-001	FABRICATION, PANEL, CLOSE OUT, AIR CONDITIONER, FMAC60S-H	2	2
17	70078-001	FABRICATION, PANEL, ACCESS, AIR CONDITIONER, FMAC60S-H	2	1
16	70075-001	FABRICATION, BRACKET, WATER COIL, FMAC60/120/180S-H	1	1
15	70073-012	FABRICATION, PANEL, CORNER, AIR CONDITIONER, FMAC60S-H	1	1
14	70073-002	FABRICATION, PANEL, CORNER, AIR CONDITIONER, FMAC60S-H	1	1
13	70073-001	FABRICATION, PANEL, CORNER, AIR CONDITIONER, FMAC60S-H	2	2
12	70071-001	FABRICATION, LID, AIR CONDITIONER, FMAC60S-H	-	1
11	70067-101	FABRICATION, BRACKET, BLOWER, AIR HANDLER	2	2
10	70067-001	FABRICATION, BRACKET, BLOWER, AIR HANDLER	2	2
9	60216-001	EVAPORATOR, 36000 MBTU, 17.50HX18.13W, 3 ROW	2	2
8	60131-001	GROMMET, 11/16" PUSH-IN LOCKING, NYLON	3	3
7	60071-001	STANDOFF, .385 ID X 1.406 OD X 1.00 THK, 70 DURO EPDM BLACK	4	4
6	60070-001	WASHER, .385 ID X 1.406 OD X .25 THK, 60 DURO EPDM BLACK	4	4
5	60014-001	BLOWER, PSC, FORWARD CURVE, DIRECT DRIVE, WHEEL DIA 13"	1	1
4	50011-001	FABRICATION, TUBING, AIR CONDITIONER, FM60S-H	2	2
3	41424	RIVET 3/16" DIA .062-.125" GRIP RANGE, SSB62S STAINLESS	27	27
2	20016-001	ASSEMBLY, CONTROL BOX, SELF CONTAINED, A/C, 48K-120K UNIVERSAL	1	1
1	1131943	#8-18 X 1/2" HWH #3 PT SELF DRILLING SCREW, 410 SS	80	80

FLAGSHIP MARINE, INC. BILL OF MATERIALS

Flagship Marine
CORPORATION
EST. 1984

FLAGSHIP MARINE, INC.
2427 SE DIXIE HIGHWAY
STUART | FLORIDA | 34996 | USA
(772) 283-1609 | (800) 319-6426
FAX (772) 283-4611

PROPRIETARY AND CONFIDENTIAL

THIS DOCUMENT CONTAINS INFORMATION PROPRIETARY TO FLAGSHIP MARINE, INC. NO PART MAY BE REPRODUCED, USED IN ANY FORM, OR STORED ELECTRONICALLY WITHOUT THE WRITTEN PERMISSION OF FLAGSHIP MARINE, INC.

UNLESS OTHERWISE SPECIFIED:	NAME	DATE
DIMENSIONS ARE IN INCHES	DRAWN	SWC 5/7/2009
TOLERANCES:	CHECKED	TCM -
FRACTIONS ± 1/32	ENG APPR.	TCM -
ANG: MACH ± 0°30' BEND ± 2°	MFG APPR.	TCM -
DECIMALS .XX ± .01	Q.A.	EAS -
.XXX ± .005	PERP	∓ .003/IN
HOLE Ø .XX ± .005	STRAIGHTNESS	∓ .005/IN
INTERPRET GEOMETRIC TOLERANCING PER: ASME Y14.5M	FLATNESS	∓ .005/IN
MATERIAL	THREADS:	EXTERNAL - CLASS 2A
FINISH	INTERNAL - CLASS 2B	∅ U.O.S
NEXT ASSY	MACHINED SURFACES:	∅ U.O.S
USED ON		
APPLICATION	DO NOT SCALE DRAWING	

TITLE: ASSEMBLY, AIR CONDITIONER FM72S-H, 39L X 28W X 26H

PART NO. 20051-001

SIZE DWG. NO. REV
B FM20051 **01**

OLD PART NO. -

SCALE: 1:12 | WGT: 631.60 LBS | SHEET 1 OF 3

2. PREFERRED LIMITS AND FITS PER ANSI B4.1 (INCHES).
1. DIMENSIONING & TOLERANCING PER ASME Y14.5M.
NOTES:

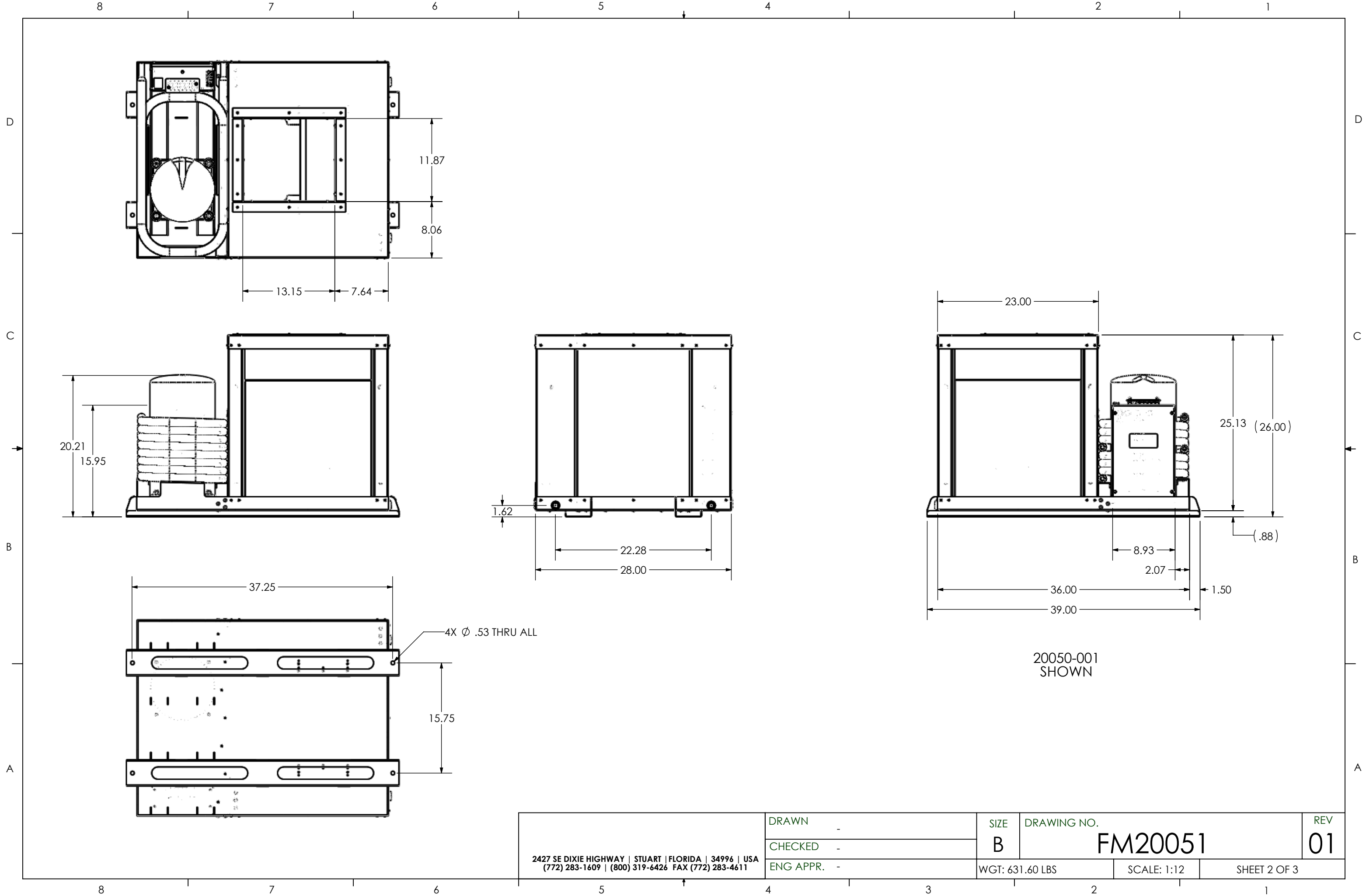

2427 SE DIXIE HIGHWAY STUART FLORIDA 34996 USA (772) 283-1609 (800) 319-6426 FAX (772) 283-4611	DRAWN -	SIZE	DRAWING NO.	REV
	CHECKED -	B	FM20051	01
	ENG APPR. -	WGT: 631.60 LBS	SCALE: 1:12	SHEET 2 OF 3

8 7 6 5 4 3 2 1

D
C
B
A

D
C
B
A

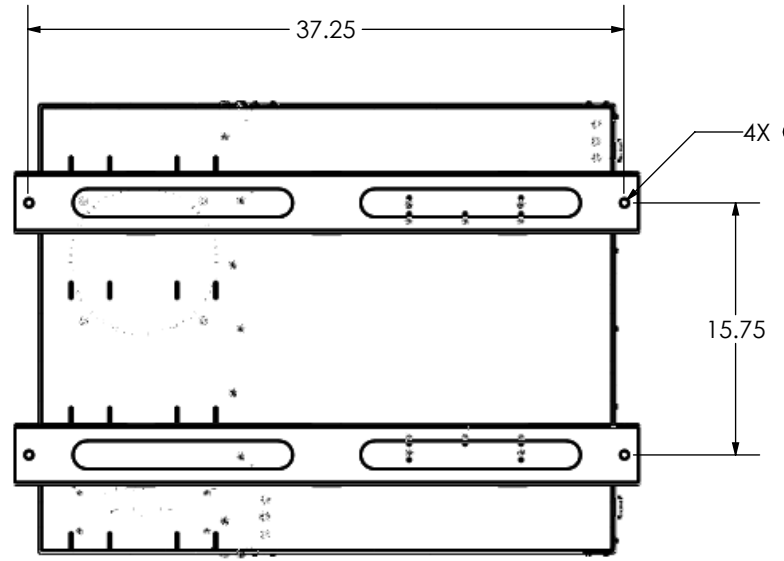
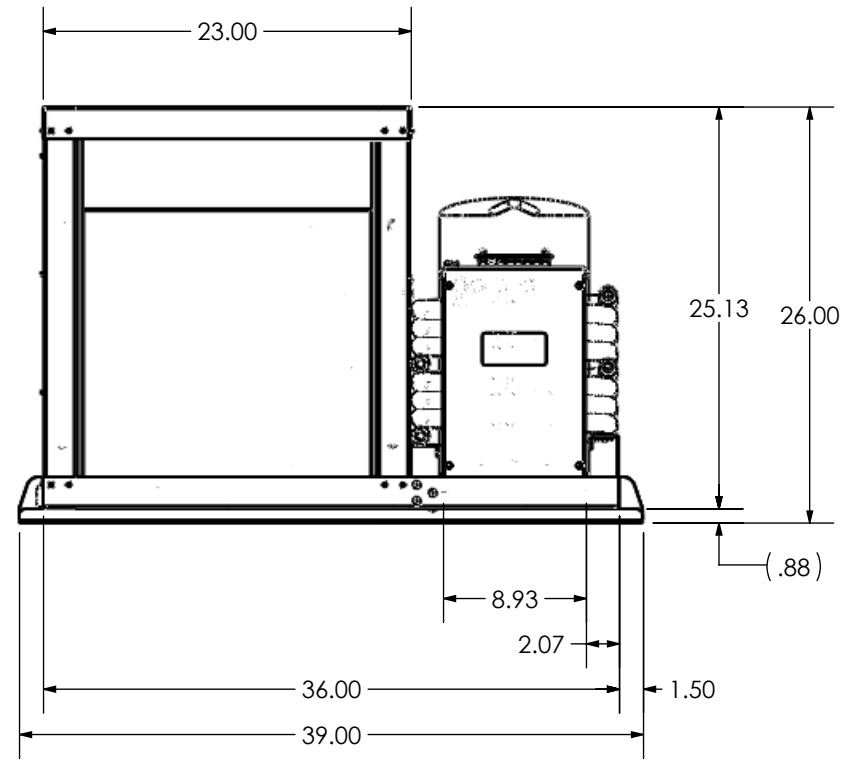
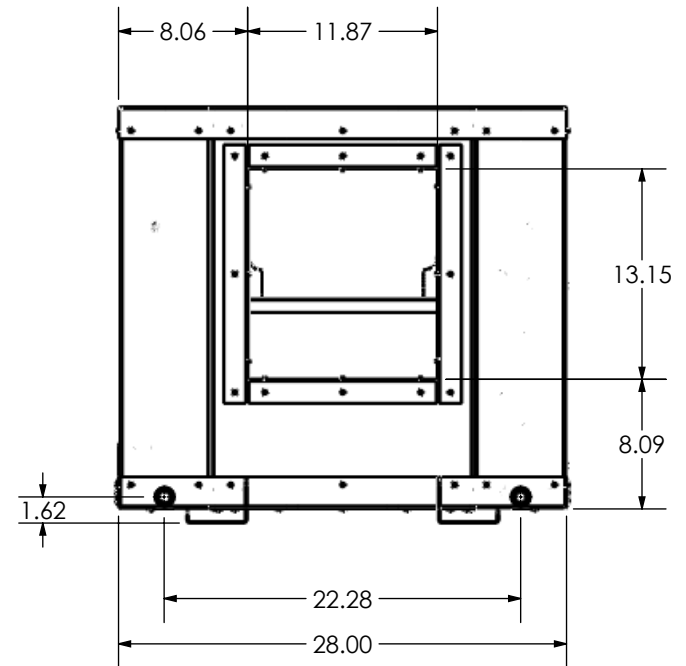
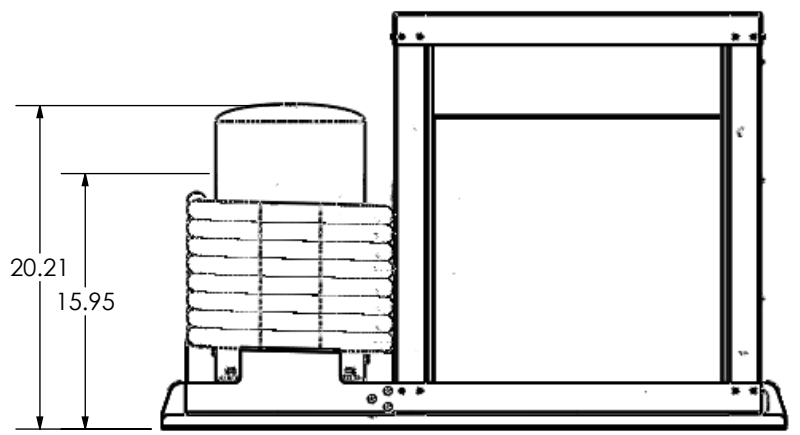
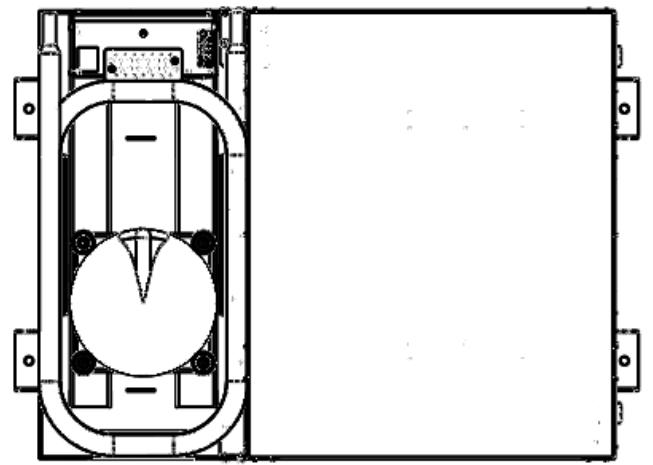

4X Ø .53 THRU ALL

20050-002
SHOWN

2427 SE DIXIE HIGHWAY STUART FLORIDA 34996 USA (772) 283-1609 (800) 319-6426 FAX (772) 283-4611	DRAWN -	SIZE	DRAWING NO.	REV
	CHECKED -	B	FM20051	01
	ENG APPR. -	WGT: 629.24 LBS	SCALE: 1:12	SHEET 3 OF 3

8 7 6 5 4 3 2 1