

8 7 6 5 4 3 2 1

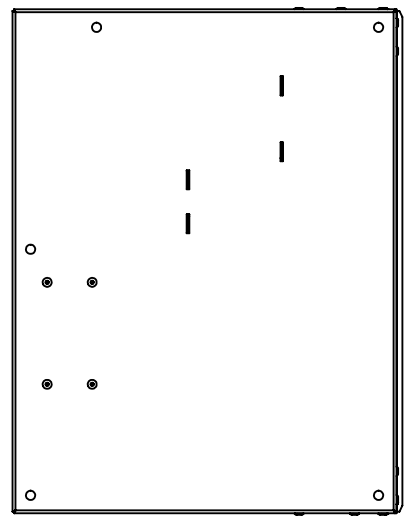
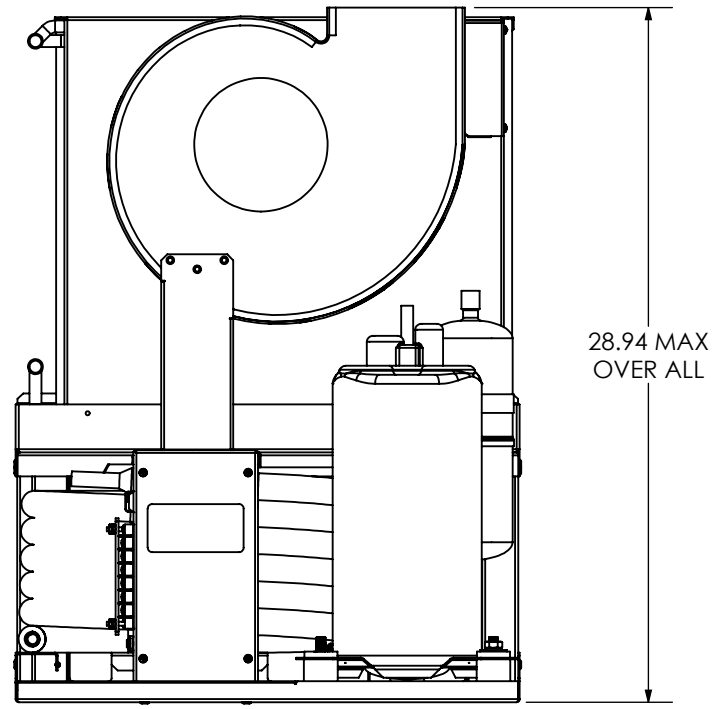
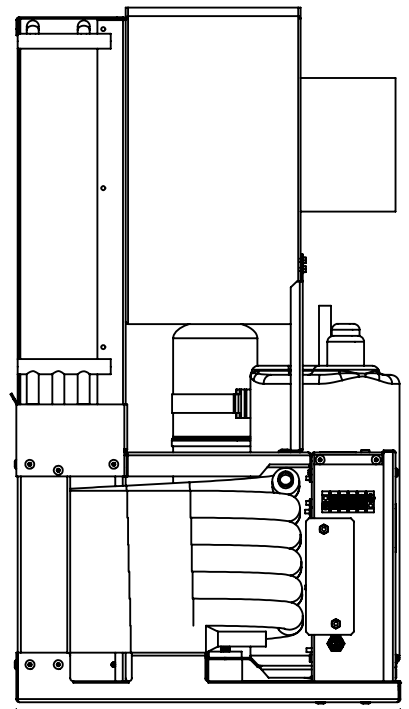
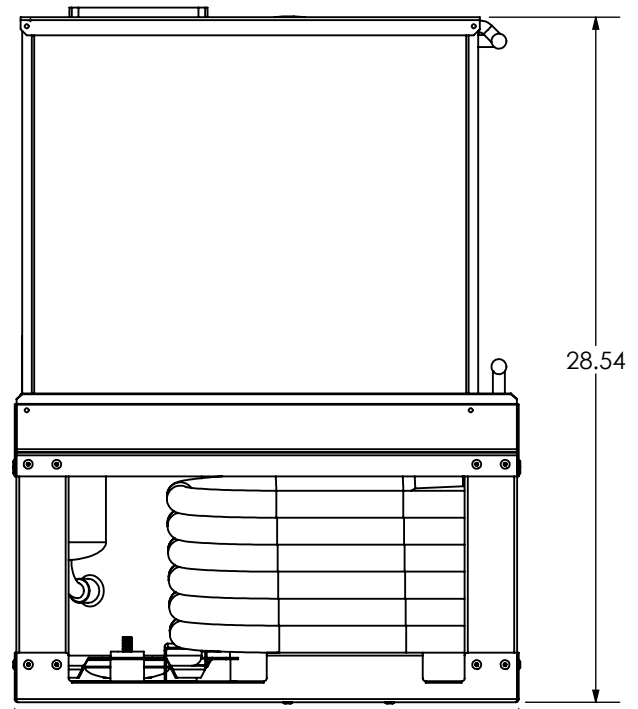
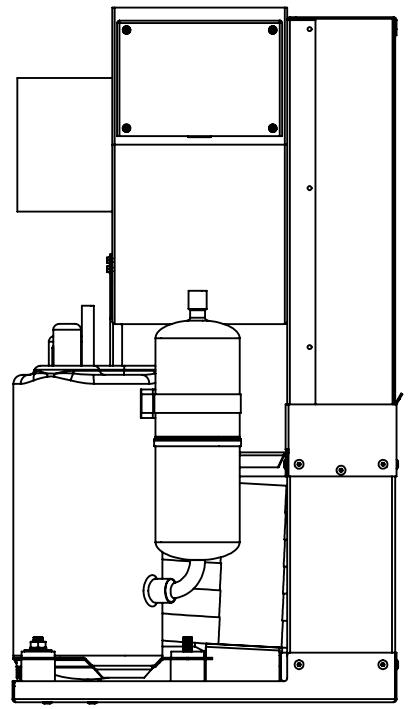
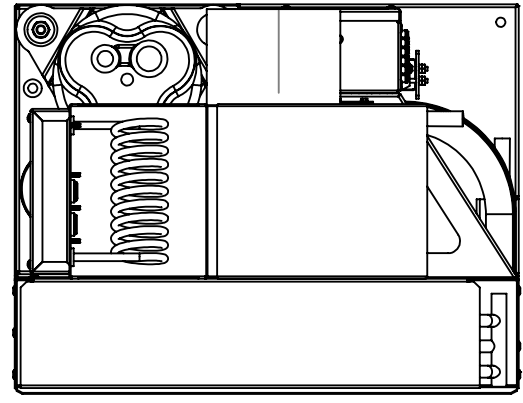

20047-011 SHOWN
SEE SHEET 1 OF 2 FOR BILL OF MATERIALS

D
C
B
A

D
C
B
A

8 7 6 5 4 3 2 1

Flagship Marine
Commercial Quality Factory Direct Prices

2427 SE DIXIE HIGHWAY | STUART | FLORIDA | 34996 | USA
(772) 283-1609 | (800) 316-6426 FAX (772) 283-4611

DRAWN	SWC
CHECKED	-
ENG APPR.	-

SIZE	DRAWING NO.
B	FM20047
WGT: 277.57 LBS	SCALE: 1:8

REV	01
SHEET 2 OF 2	