

PART NUMBER	DESCRIPTION
20027-001	ASSEMBLY, AIR CONDITIONER FM24R, 24.75L X 17.25W X 17.5H, 230V SIDE
20027-011	ASSEMBLY, AIR CONDITIONER FM24R, 24.75L X 17.25W X 17.5H, 230V SIDE, WITH OPTIONAL HEAT

FLAGSHIP MARINE, INC.				
REV.	ZONE	DESCRIPTION	DATE	ENG APPROVAL
01		INITIAL CHECK-IN	1/20/2011	

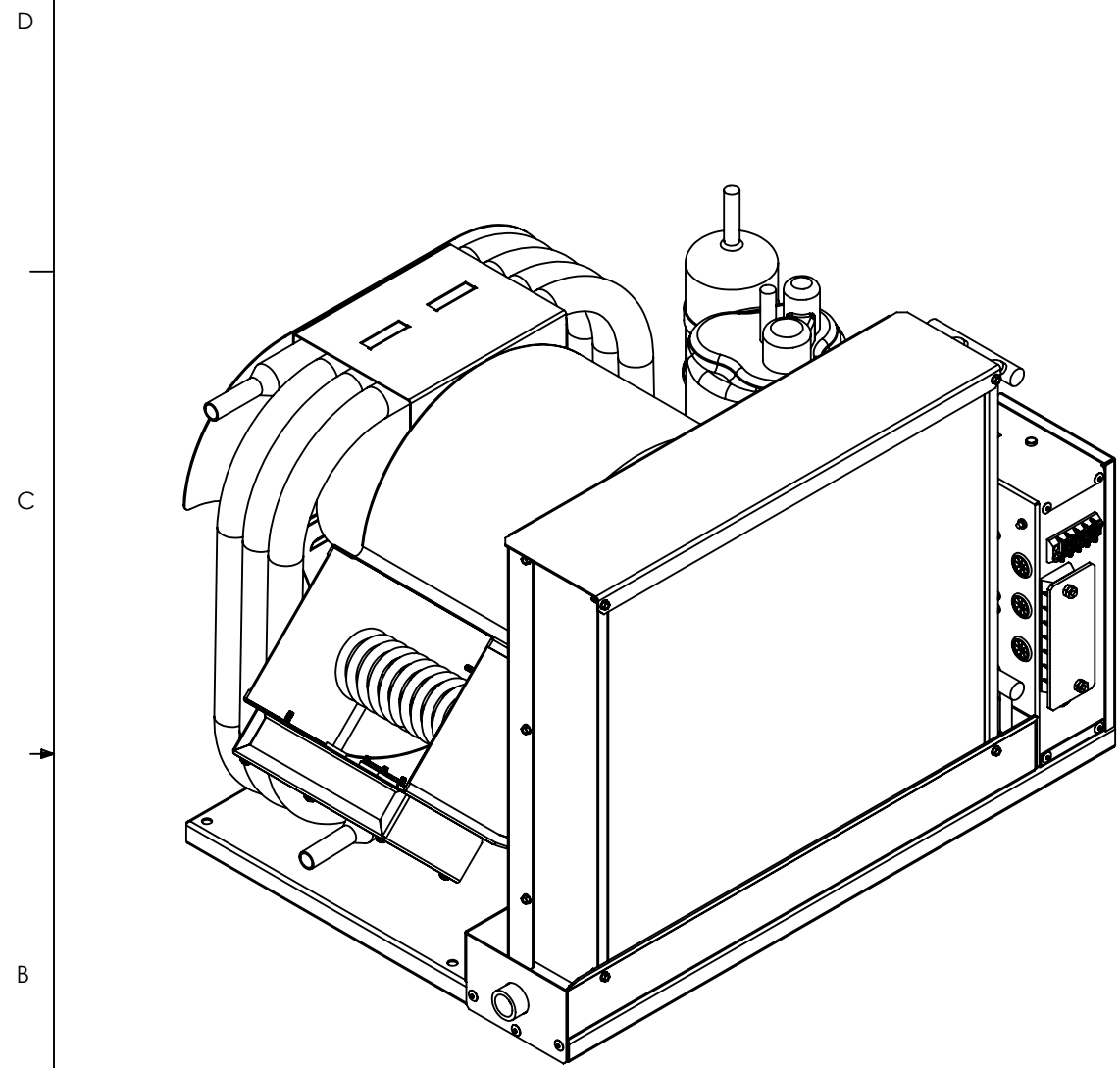

**20027-011 SHOWN
SEE SHEET 3 OF 4 FOR DIMENSIONS**

27	Selected Wide FW 0.375		6	6
26	Regular LW 0.375		3	3
25	MSHXNUT 0.375-16-D-N		3	3
24	HBOLT 0.3750-16x2x1-S		3	3
23	80101-001	WELDMENT, DRAIN PAN, EVAPORATOR, AIR CONDITIONER, FM24R, SIDE	1	1
22	70144-001	FABRICATION, BRACKET, BLOWER, AIR CONDITIONER, FM24R	1	1
21	70143-001	FABRICATION, SUPPORT, BASE, AIR CONDITIONER, FM24R	1	1
20	70141-001	FABRICATION, BRACKET, SIDE, CONDENSER, AIR CONDITIONER, FM24R - FM60R	1	1
19	70139-001	FABRICATION, LID, ENCLOSURE, HEATER COIL, AIR CONDITIONER, FM24R - FM60R	-	1
18	70138-001	FABRICATION, ENCLOSURE, HEATER COIL, AIR CONDITIONER, FM24R - FM60R	-	1
17	70114-001	FABRICATION, SHROUD, EVAPORATOR, AIR CONDITIONER, FM24R, SIDE	1	1
16	70112-001	FABRICATION, BASE, AIR CONDITIONER, FM24R	1	1
15	70093-001	DETAIL, PLATE, DECORATIVE CONDENSER COVER, FM24R	1	1
14	60215-001	EVAPORATOR, 24000 MBTU, 16HX17W, 3 ROW	1	1
13	60131-001	GROMMET, 11/16" PUSH-IN LOCKING, NYLON	-	1
12	60071-001	STANDOFF, .385 ID X 1.406 OD X 1.00 THK, 70 DURO EPDM BLACK	3	2
11	60070-001	WASHER, .385 ID X 1.406 OD X .25 THK, 60 DURO EPDM BLACK	3	3
10	60062-001	THERMAL LIMIT SWITCH, 130 DEGREE	-	1
9	60060-001	THERMAL LIMIT SWITCH, 110 DEGREE	-	1
8	60035-001	HEATER ELEMENT, COIL, 74"L, 8MM, 4000W, 230VAC, DBL END THRD BULKHEAD	-	1
7	60012-001	BLOWER, PSC, FORWARD CURVE, DIRECT DRIVE, WHEEL DIA 8 1/4"	1	1
6	50006-001	FABRICATION, TUBING, AIR CONDITIONER, FM24R	1	1
5	2K28S3R236A-7B	COMPRESSOR, 1PH, 60 Hz, 230V	1	1
4	20015-001	ASSEMBLY, CONTROL BOX, SELF CONTAINED, A/C, UNIVERSAL	1	1
3	1131943	#8-18 X 1/2" HWH #3 PT SELF DRILLING SCREW, 410 SS	16	21
2	72396	#8-32 x 3/8" PHMS 18-8 SS	-	4
1	41424	RIVET 3/16" DIA .062-.125" GRIP RANGE, SSB62S STAINLESS	23	23

ITEM NO.	PART NUMBER	DESCRIPTION	20027-001/QTY.	20027-011/QTY.
----------	-------------	-------------	----------------	----------------

FLAGSHIP MARINE, INC. BILL OF MATERIALS

<p>FLAGSHIP MARINE, INC. 2427 SE DIXIE HIGHWAY STUART FLORIDA 34996 USA (772) 283-1609 (800) 316-6426 FAX (772) 283-4611</p> <p>PROPRIETARY AND CONFIDENTIAL</p> <p>THIS DOCUMENT CONTAINS INFORMATION PROPRIETARY TO FLAGSHIP MARINE, INC. NO PART MAY BE REPRODUCED, USED IN ANY FORM, OR STORED ELECTRONICALLY WITHOUT THE WRITTEN PERMISSION OF FLAGSHIP MARINE, INC.</p>			UNLESS OTHERWISE SPECIFIED: DIMENSIONS ARE IN INCHES TOLERANCES: FRACTIONS ± 1/32 ANG: MACH ± 0°30' BEND ± 2° DECIMALS .XX ± .01 .XXX ± .005 HOLE Ø .XX ± .005		NAME	DATE	TITLE: ASSEMBLY, AIR CONDITIONER FM24R, 24.75L X 17.25W X 17.5H, 230V SIDE, WITH OPTIONAL HEAT PART NO. 20027-XX1	
			INTERPRET GEOMETRIC TOLERANCING PER: ASME Y14.5M		DRAWN	SWC		8/2/2010
			MATERIAL		CHECKED	TCM		-
			FINISH NONE		ENG APPR.	TCM		-
	NEXT ASSY	USED ON		MFG APPR.	TCM	-	SIZE B DWG. NO. FM20027 REV 01 OLD PART NO. - SCALE: 1:6 WGT: 191.97 LBS SHEET 1 OF 4	
	APPLICATION	DO NOT SCALE DRAWING		Q.A.	EAS	-		
					PERP STRAIGHTNESS ± .003/IN FLATNESS ± .005/IN THREADS: EXTERNAL - CLASS 2A INTERNAL - CLASS 2B MACHINED SURFACES: ✓ U.O.S			

4. NO DEVIATION FROM THIS DESIGN WILL BE ACCEPTED WITHOUT THE PRIOR WRITTEN CONSENT OF FLAGSHIP MARINE, INC. (NINGUNA DESVIACION SE PERMITERA SIN AUTORIZACION ESCRITA PREVIA DE FLAGSHIP MARINE, INC.)
3. NO SHARP EDGES PERMITTED.
2. PREFERRED LIMITS AND FITS PER ANSI B4.1 (INCHES).
1. DIMENSIONING & TOLERANCING PER ASME Y14.5M.
- NOTES:

PART NUMBER	DESCRIPTION
20027-002	ASSEMBLY, AIR CONDITIONER FM24R, 24.75L X 17.25W X 17.5H, 230V TOP
20027-012	ASSEMBLY, AIR CONDITIONER FM24R, 24.75L X 17.25W X 17.5H, 230V TOP, WITH OPTIONAL HEAT

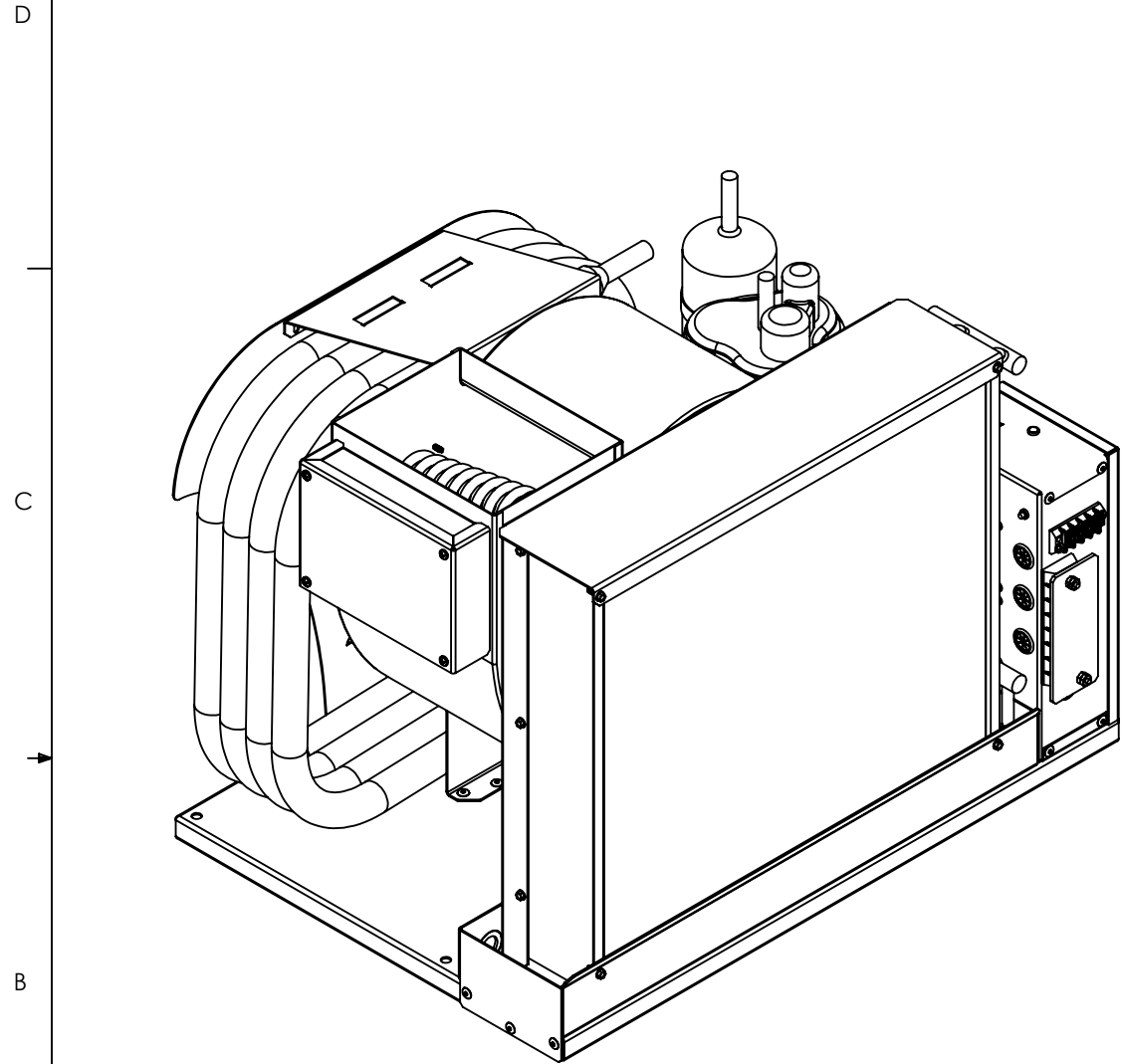

20027-012 SHOWN
SEE SHEET 4 OF 4 FOR DIMENSIONS

27	Selected Wide FW 0.375		6	6
26	Regular LW 0.375		3	3
25	MSHXNUT 0.375-16-D-N		3	3
24	HBOLT 0.3750-16x2x1-S		3	3
23	80101-002	WELDMENT, DRAIN PAN, EVAPORATOR, AIR CONDITIONER, FM24R, TOP	1	1
22	70144-001	FABRICATION, BRACKET, BLOWER, AIR CONDITIONER, FM24R	1	1
21	70143-001	FABRICATION, SUPPORT, BASE, AIR CONDITIONER, FM24R	1	1
20	70142-001	FABRICATION, BRACKET, TOP, CONDENSER, AIR CONDITIONER, FM24R - FM60R	1	1
19	70139-001	FABRICATION, LID, ENCLOSURE, HEATER COIL, AIR CONDITIONER, FM24R - FM60R	1	-
18	70138-001	FABRICATION, ENCLOSURE, HEATER COIL, AIR CONDITIONER, FM24R - FM60R	1	-
17	70114-002	FABRICATION, SHROUD, EVAPORATOR, AIR CONDITIONER, FM24R, TOP	1	1
16	70112-001	FABRICATION, BASE, AIR CONDITIONER, FM24R	1	1
15	70093-001	DETAIL, PLATE, DECORATIVE CONDENSER COVER, FM24R	1	1
14	60215-001	EVAPORATOR, 24000 MBTU, 16HX17W, 3 ROW	1	1
13	60131-001	GROMMET, 11/16" PUSH-IN LOCKING, NYLON	1	-
12	60071-001	STANDOFF, .385 ID X 1.406 OD X 1.00 THK, 70 DURO EPDM BLACK	2	2
11	60070-001	WASHER, .385 ID X 1.406 OD X .25 THK, 60 DURO EPDM BLACK	3	3
10	60062-001	THERMAL LIMIT SWITCH, 130 DEGREE	1	-
9	60060-001	THERMAL LIMIT SWITCH, 110 DEGREE	1	-
8	60035-001	HEATER ELEMENT, COIL, 74"L, 8MM, 4000W, 230VAC, DBL END THRD BULKHEAD	1	-
7	60012-001	BLOWER, PSC, FORWARD CURVE, DIRECT DRIVE, WHEEL DIA 8 1/4"	1	1
6	50006-001	FABRICATION, TUBING, AIR CONDITIONER, FM24R	1	1
5	2K28S3R236A-7B	COMPRESSOR, 1PH, 60 Hz, 230V	1	1
4	20015-001	ASSEMBLY, CONTROL BOX, SELF CONTAINED, A/C, UNIVERSAL	1	1
3	1131943	#8-18 X 1/2" HWH #3 PT SELF DRILLING SCREW, 410 SS	20	16
2	72396	#8-32 x 3/8" PHMS 18-8 SS	4	-
1	41424	RIVET 3/16" DIA .062-.125" GRIP RANGE, SSB62S STAINLESS	23	23

ITEM NO.	PART NUMBER	DESCRIPTION	20026-012/QTY.	20026-002/QTY.
----------	-------------	-------------	----------------	----------------

FLAGSHIP MARINE, INC. BILL OF MATERIALS

<p>FLAGSHIP MARINE, INC. 2427 SE DIXIE HIGHWAY STUART FLORIDA 34996 USA (772) 283-1609 (800) 316-6426 FAX (772) 283-4611</p> <p>PROPRIETARY AND CONFIDENTIAL</p> <p>THIS DOCUMENT CONTAINS INFORMATION PROPRIETARY TO FLAGSHIP MARINE, INC. NO PART MAY BE REPRODUCED, USED IN ANY FORM, OR STORED ELECTRONICALLY WITHOUT THE WRITTEN PERMISSION OF FLAGSHIP MARINE, INC.</p>			UNLESS OTHERWISE SPECIFIED: DIMENSIONS ARE IN INCHES TOLERANCES: FRACTIONS ± 1/32 ANG: MACH ± 0°30' BEND ± 2° DECIMALS .XX ± .01 .XXX ± .005 HOLE Ø .XX ± .005	DRAWN	NAME	DATE	TITLE: ASSEMBLY, AIR CONDITIONER FM24R, 24.75L X 17.25W X 17.5H, 230V TOP, WITH OPTIONAL HEAT PART NO. 20027-XX2
			INTERPRET GEOMETRIC TOLERANCING PER: ASME Y14.5M	CHECKED	TCM	-	
			MATERIAL	ENG APPR.	TCM	-	
			FINISH NONE	MFG APPR.	TCM	-	
	NEXT ASSY	USED ON	Q.A.	EAS	-	PERP STRAIGHTNESS ± .003/IN FLATNESS ± .005/IN THREADS: EXTERNAL - CLASS 2A INTERNAL - CLASS 2B MACHINED SURFACES: √ U.O.S	SIZE B DWG. NO. FM20027 REV 01
	APPLICATION	DO NOT SCALE DRAWING				OLD PART NO. - SCALE: 1:6 WGT: 191.89 LBS SHEET 2 OF 4	

4. NO DEVIATION FROM THIS DESIGN WILL BE ACCEPTED WITHOUT THE PRIOR WRITTEN CONSENT OF FLAGSHIP MARINE, INC. (NINGUNA DESVIACION SE PERMITERA SIN AUTORIZACION ESCRITA PREVIA DE FLAGSHIP MARINE, INC.)

3. NO SHARP EDGES PERMITTED.

2. PREFERRED LIMITS AND FITS PER ANSI B4.1 (INCHES).

1. DIMENSIONING & TOLERANCING PER ASME Y14.5M.

NOTES:

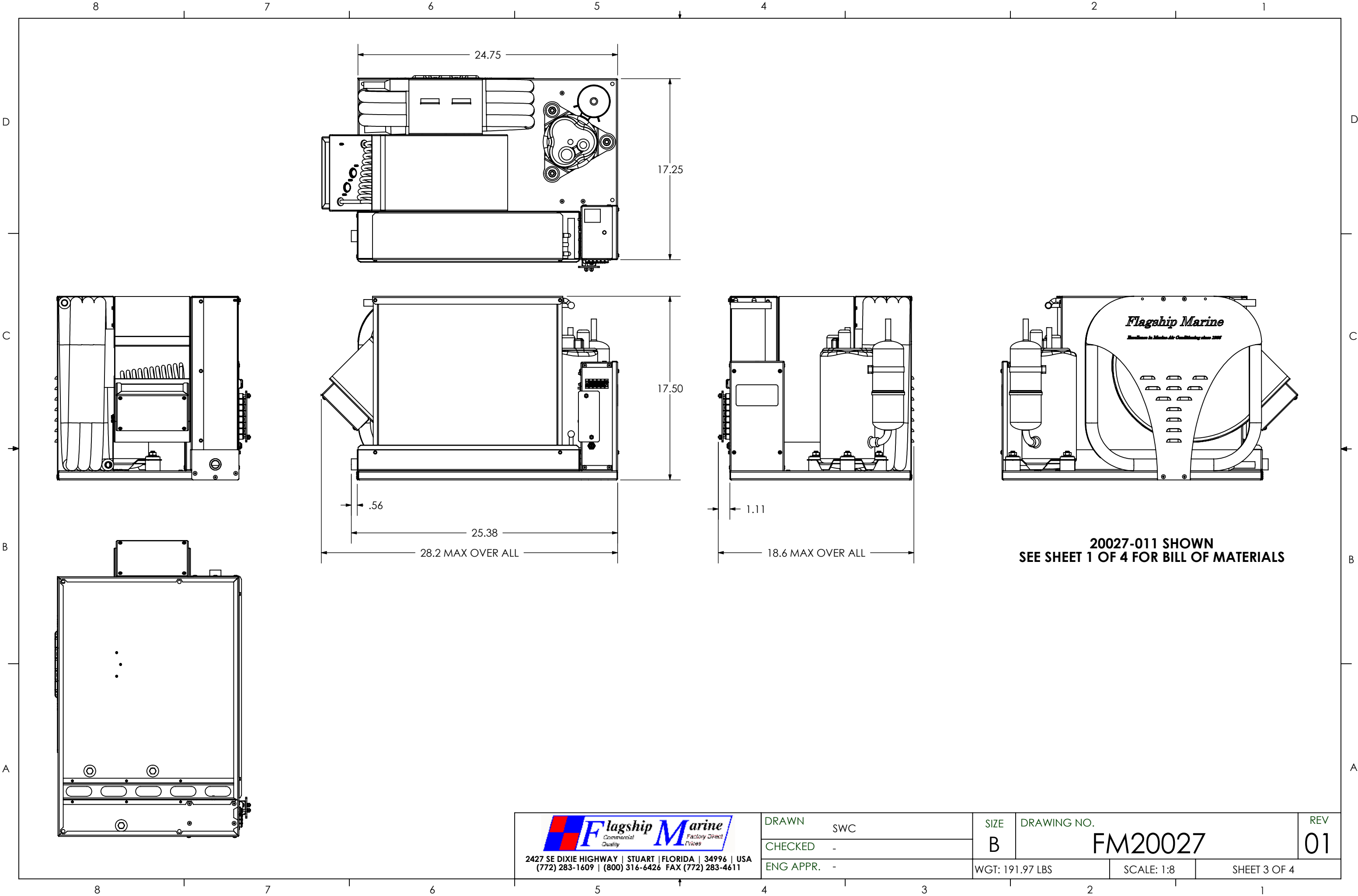

20027-011 SHOWN
SEE SHEET 1 OF 4 FOR BILL OF MATERIALS

 <p>Commercial Quality Factory Direct Prices</p> <p>2427 SE DIXIE HIGHWAY STUART FLORIDA 34996 USA (772) 283-1609 (800) 316-6426 FAX (772) 283-4611</p>	DRAWN SWC	SIZE B	DRAWING NO. FM20027	REV 01
	CHECKED -	WGT: 191.97 LBS	SCALE: 1:8	SHEET 3 OF 4
ENG APPR. -				

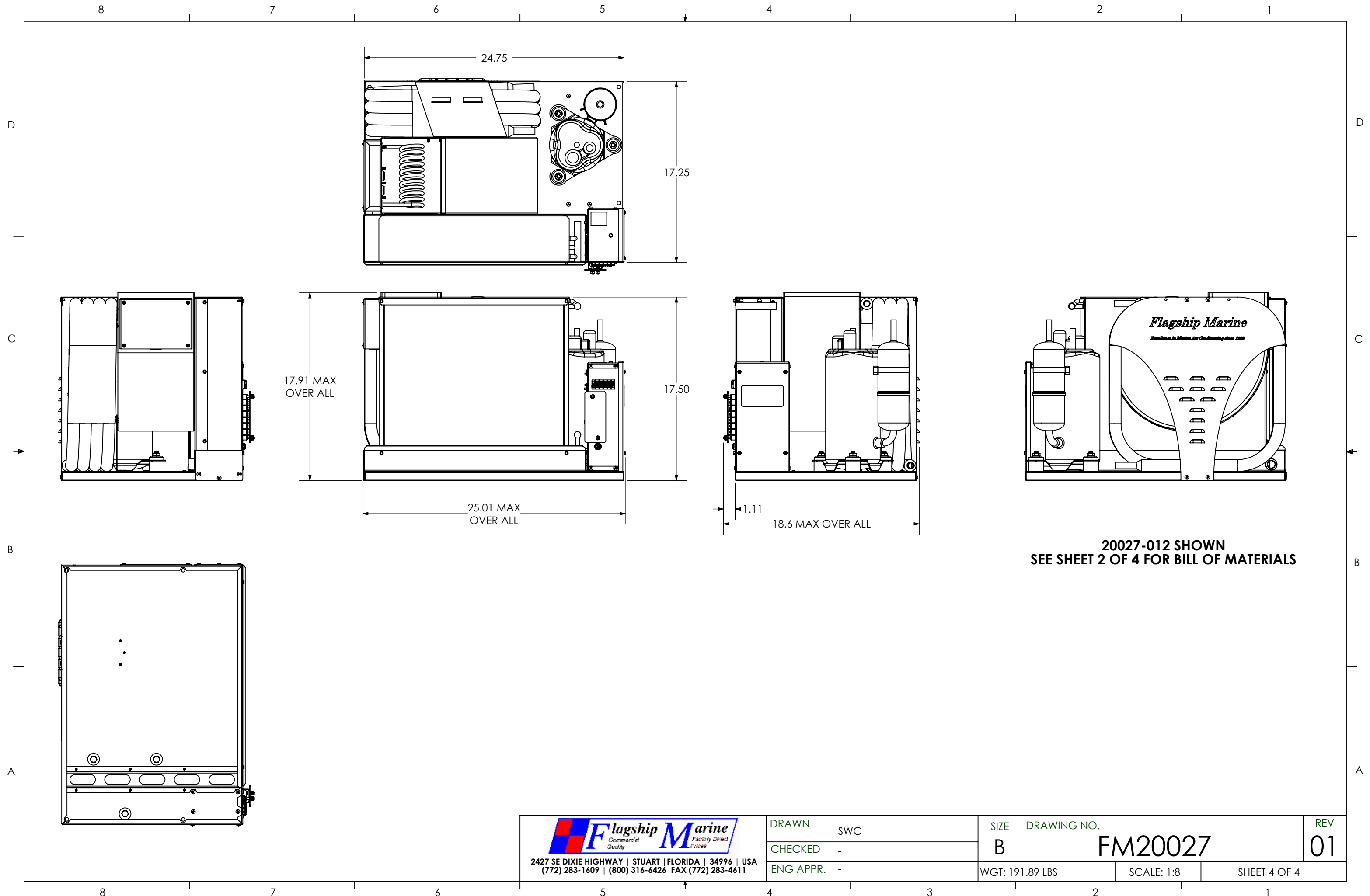

20027-012 SHOWN
SEE SHEET 2 OF 4 FOR BILL OF MATERIALS

 <p>Commercial Quality Factory Direct Prices</p> <p>2427 SE DIXIE HIGHWAY STUART FLORIDA 34996 USA (772) 283-1609 (800) 316-6426 FAX (772) 283-4611</p>	DRAWN	SWC	SIZE	DRAWING NO.	REV
	CHECKED	-	B	FM20027	01
ENG APPR.	-	WGT: 191.89 LBS	SCALE: 1:8	SHEET 4 OF 4	