

PART NUMBER	DESCRIPTION
20018-001	ASSEMBLY, AIR CONDITIONER, FM18R-LP, 22.5L X 15.5W X 10.5H, 120V SIDE
20018-011	ASSEMBLY, AIR CONDITIONER, FM18R-LP, 22.5L X 15.5W X 10.5H, 120V SIDE, WITH OPTIONAL HEAT

FLAGSHIP MARINE, INC.				
REV.	ZONE	DESCRIPTION	DATE	ENG APPROVAL
01		INITIAL CHECK-IN	1/31/2011	

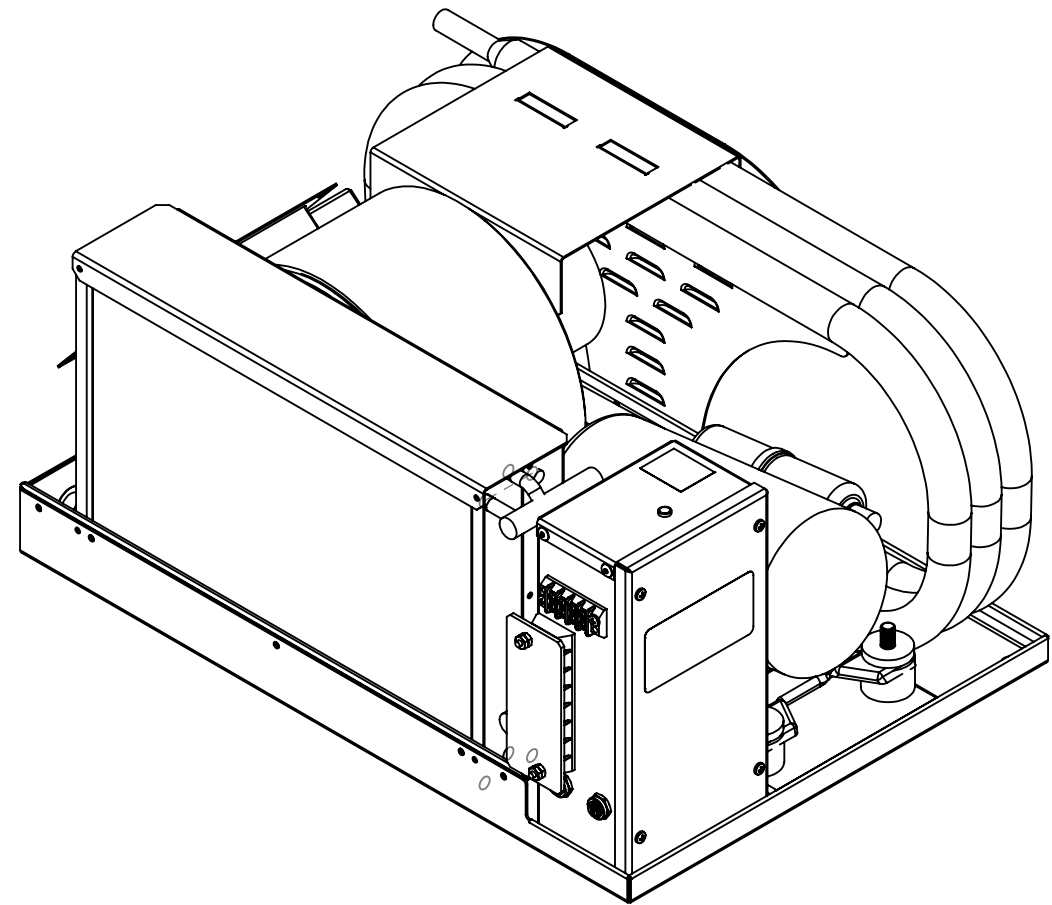

**20018-011 SHOWN
SEE SHEET 2 OF 2 FOR DIMENSIONS**

2. PREFERRED LIMITS AND FITS PER ANSI B4.1 (INCHES).
1. DIMENSIONING & TOLERANCING PER ASME Y14.5M.
NOTES:

19	60131-001	GROMMET, 11/16" PUSH-IN LOCKING, NYLON	-	1
18	60060-001	THERMAL LIMIT SWITCH, 110 DEGREE	-	1
17	60062-001	THERMAL LIMIT SWITCH, 130 DEGREE	-	1
16	60032-001	HEATER ELEMENT, COIL, 45"L, 8MM, 2000W, 120VAC, DBL END THRD BULKHEAD	-	1
15	70086-001	FABRICATION, LID, ENCLOSURE, HEATER COIL, AIR CONDITIONER, FM9R	-	1
14	70085-001	FABRICATION, ENCLOSURE, HEATER COIL, AIR CONDITIONER, FM9R	-	1
13	80099-001	WELDMENT, DRAIN PAN, EVAPORATOR, AIR CONDITIONER, FM18R-LP, SIDE	1	1
12	60070-001	WASHER, .385 ID X 1.406 OD X .25 THK, 60 DURO EPDM BLACK	2	2
11	60071-001	STANDOFF, .385 ID X 1.406 OD X 1.00 THK, 70 DURO EPDM BLACK	2	2
10	70095-001	DETAIL, PLATE, DECORATIVE CONDENSER COVER, FM18R-LP	1	1
9	1450A2189	COMPRESSOR, LOW PROFILE, 115V	1	1
8	70133-001	FABRICATION, BRACKET, BLOWER, AIR CONDITIONER, FM18R-LP	1	1
7	20015-002	ASSEMBLY, CONTROL BOX, SELF CONTAINED, A/C, UNIVERSAL	1	1
6	70134-001	FABRICATION, BRACKET, CONDENSOR, AIR CONDITIONER, FM18R-LP	1	1
5	50014-001	FABRICATION, TUBING, AIR CONDITIONER, FM18R-LP	1	1
4	60006-001	BLOWER, PSC, SHADED POLE, 1TDT2, 115V	1	1
3	70132-001	FABRICATION, SHROUD, EVAPORATOR, AIR CONDITIONER, FM18R-LP	1	1
2	60213-001	EVAPORATOR, 18000LP MBTU, 10HX14W, 3 ROW	1	1
1	80159-001	WELDMENT, BASE, AIR CONDITIONER, FM18R-LP	1	1

ITEM NO.	PART NUMBER	DESCRIPTION	20018-001/QTY.	20018-011/QTY.
----------	-------------	-------------	----------------	----------------

FLAGSHIP MARINE, INC. BILL OF MATERIALS

<p>FLAGSHIP MARINE, INC. 2427 SE DIXIE HIGHWAY STUART FLORIDA 34996 USA (772) 283-1609 (800) 316-6426 FAX (772) 283-4611</p> <p>PROPRIETARY AND CONFIDENTIAL THIS DOCUMENT CONTAINS INFORMATION PROPRIETARY TO FLAGSHIP MARINE, INC. NO PART MAY BE REPRODUCED, USED IN ANY FORM, OR STORED ELECTRONICALLY WITHOUT THE WRITTEN PERMISSION OF FLAGSHIP MARINE, INC.</p>	-	-	UNLESS OTHERWISE SPECIFIED: DIMENSIONS ARE IN INCHES TOLERANCES: FRACTIONS ± 1/32 ANG: MACH ± 0°30' BEND ± 2° DECIMALS .XX ± .01 .XXX ± .005 HOLE Ø .XX ± .005	DRAWN	SWC	8/2/2010	TITLE: ASSEMBLY, AIR CONDITIONER, SIDE, FM18R-LP, 26.5L X 14.5W X 10.5H PART NO. 20018-0XX
	-	-	INTERPRET GEOMETRIC TOLERANCING PER: ASME Y14.5M	CHECKED	TCM	-	
	-	-	MATERIAL	ENG APPR.	TCM	-	
	-	-	FINISH	MFG APPR.	TCM	-	
<p>PERP STRAIGHTNESS .003/IN FLATNESS .005/IN THREADS: EXTERNAL - CLASS 2A INTERNAL - CLASS 2B MACHINED SURFACES: ✓ U.O.S</p>	<p>SIZE B</p> <p>DWG. NO. FM20018</p> <p>REV 01</p> <p>OLD PART NO. -</p> <p>SCALE: 1:5 WGT: 114.31 LBS SHEET 1 OF 2</p>						

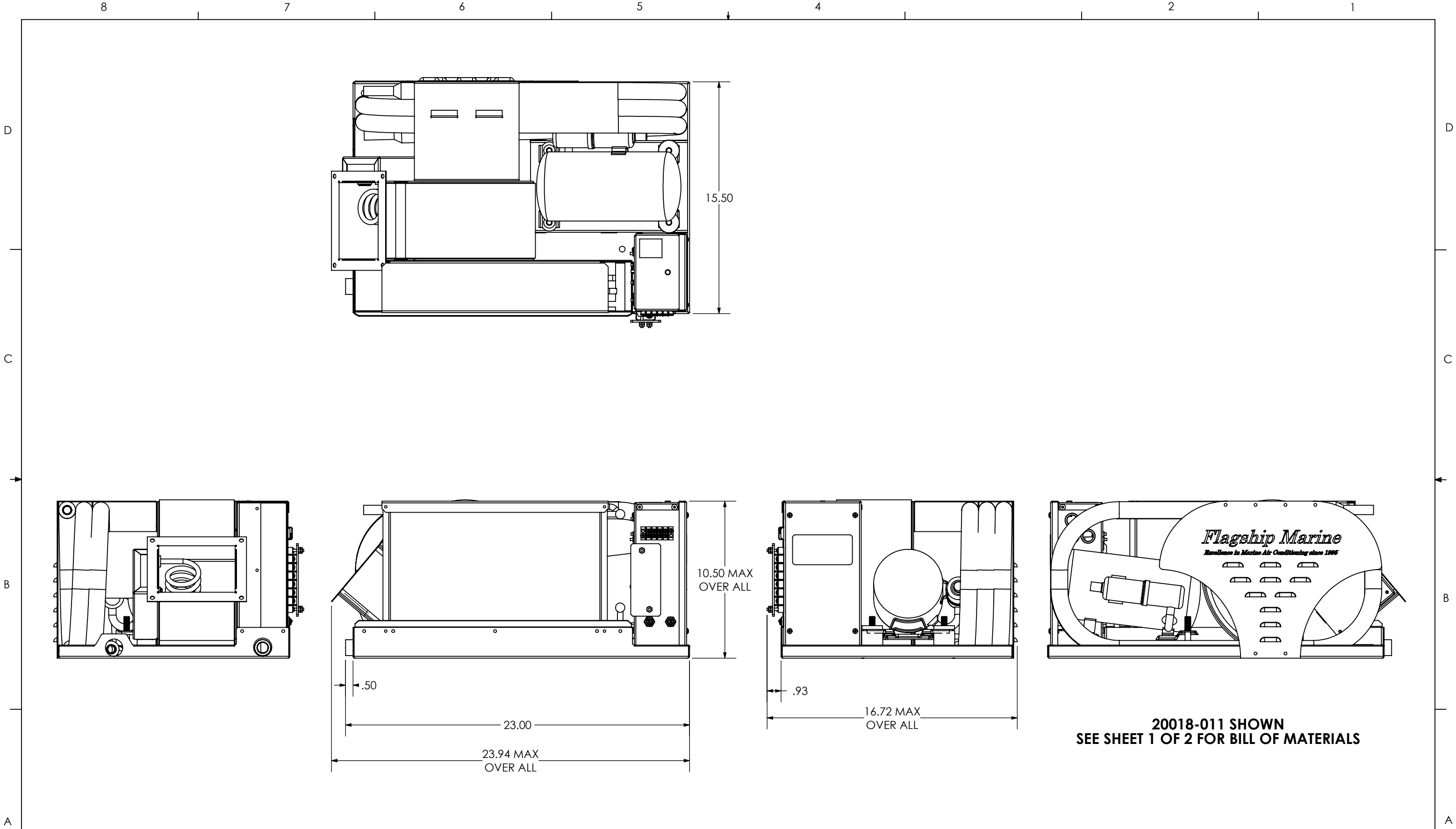

Flagship Marine
Commercial Quality Factory Direct Prices

2427 SE DIXIE HIGHWAY | STUART | FLORIDA | 34996 | USA
(772) 283-1609 | (800) 316-6426 FAX (772) 283-4611

DRAWN	SWC	SIZE	DRAWING NO.	REV
CHECKED	-	B	FM20018	01
ENG APPR.	-	WGT: 114.31 LBS	SCALE: 1:6	SHEET 2 OF 2